

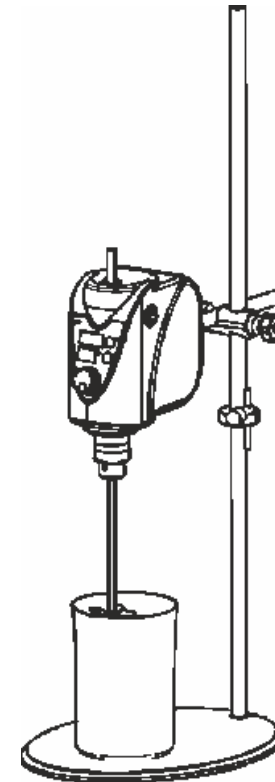

ISO 9001:2015 & OHSAS 18001:2007
Certified Co.

Digital Overhead Stirrer

OPERATING MANUAL
6000.EU.01



CE
certified

Glassco Laboratory Equipment Pvt. Ltd.

Vill. Manglai, P.O Khudda Kalan, Ambala Cantt 133004 (INDIA)

Website: glasscolabs.in, glasscolabs.com

E-mail: info@glasscolabs.in, support@glasscolabs.in,
techinfo@glasscolabs.com

PREFACE

Thanks for choosing digital overhead stirrer 6000.EU.01. This operation manual describes function and operation of the instrument. In order to use the instrument properly, please read this manual carefully before operating the Instrument.

Opening Check

Please check the instrument and appendix with the packing list when you first open the packing case. If anything does not match with the packing list, please contact with the vendor or the producer.

Safety Warnings and Guidelines

1. Important operation information of the security

Users should have an entire conception of how to use the instrument properly before operating it. Please read this operation manual carefully before using the instrument.



It is forbidden operating before read the operation manual. Read the guidelines and directions below and carry out the countermeasure according to them.

2 Security

The operation, maintenance and repair of the Instrument should comply with the basic guidelines and the remarked warning below. Otherwise, it will affect the scheduled using life of the Instrument and the protection provided.



This product is a normal and an indoor Instrument which conforms to Standard B style- I type- GB9706.1.



Before operation, read the manual carefully. These units are designed for using in the laboratory environments by who're knowledgeable in safe laboratory practices



The operator should not open or repair the instrument by himself. Otherwise, the instrument will lose the qualification of repair guarantee or cause accidents. The company will repair the instrument based on warranty description.



A.C. power's grounding should be reliable to safeguard against an electric shock. The 3-pin plug supplied with thermo-shaker's power cable is a safety device that should be matched with a suitable grounded socket.



The instrument should be put in the place where of low temperature, little dust, no water, no sunshine or hard light, and of good aeration, no corrosively gas or strong disturbing magnetic field, and far away from central heating, camp stove and other hot resource. Do not put the instrument in wet and dusty place. The vent on the instrument is designed for aeration. Do not wall up or cover the vent.



Power off when operation finished. If do not use the instrument for a long period, pull off the connector plug, cover a piece of cloth on the instrument to prevent from dust.

Pull the connector plug from the jack at once in the following case, and contact the vendor.



- There is some liquid flowing into the instrument;
- Drenched or fire burned;
- Abnormal operation: such as abnormal sound or smell;
- Instrument dropping or outer shell damaged;
- The function has obviously changed.

3. Instruments Maintenance

The instrument and the accessories should be cleaned by cloth drenched with alcohol.

If there are smutches on the instrument, clean them with cloth.

4. After Service

1) Warranty Description

Within one month of delivery, the company is responsible of exchange for breakdown caused by material or manufacture.

Within 12 months of delivery, the company is responsible of free repair for breakdown caused by material or manufacture. Proven with defect under warranty, the company will exchange the instrument or free repair it alternatively.

Instrument under warranty period should be delivered to the appointed maintenance department by user. Freight from user to maintenance department will be borne by user. Freight for instrument resent to user will be borne by the company.

Repair out of warranty will be charged reasonable cost.

2) Warranty Coverage

Breakdown due to improper use, operation in inappropriate conditions, maintain or refitting without authorization are not in warranty coverage.

CONTENTS

CHAPTER 1 INTRODUCTION _____	1
CHAPTER 2 SPECIFICATIONS _____	2
1. THE NORMAL OPERATION CONDITION_____	2
2. THE BASIC PARAMETERS AND SPECIFICATIONS_____	2
3. OPTIONAL PROPELLERS_____	2
CHAPTER 3 PREPARATION _____	3
1. STRUCTURE DESCRIPTION_____	3
2. KEYBOARD AND DISPLAY PANEL_____	4
3. KEY FUNCTION_____	4
4. INSTALLATION_____	4
CHAPTER 4 OPERATION GUIDE _____	7
1. SPEED AND TIME SETTING_____	7
2. STOP / START_____	8
CHAPTER 5 FAILURE ANALYSIS AND TROUBLE SHOOTING _____	9
APPENDIX A : WIRING DIAGRAM OF 6000.EU.01 _____	10

Chapter 1 Introduction

Digital overhead stirrer is suitable for middle and high viscosity liquid or solid-liquid mixture. It mainly used in chemical synthesis, pharmaceutical, physical and chemical analysis, petrochemical, cosmetics, health products, food, biotechnology, and so on

Features:

1. Backlit LED display speed and time. Convenient for reading and operating.
2. Precise control speed, accuracy within 3rpm. Accurately display actual/setting speed.
3. Constant speed. Torque is automatically adjusted according to the sample viscosity to keep the setting speed.
4. Full explosion-proof equipment. Explosion-proof brushless DC motor to ensure lab safety.
5. Anti-spill samples, smooth start, effectively prevent spilling.
6. Closed shell to prevent liquid from entering the machine internal corrosion circuit, ensure safe operation. Long time continuous and stable operation.
7. Overload protection and motor protection. Circuit auto cut-off when overload, short circuit and abnormal speed occur.
8. Clockwise counterclockwise stirring exchange mode. Perfect stirring effect.

2. The Basic Parameters and Specifications

1. The Normal Operation Condition

Ambient Temperature : 4C 45C
Relative Humidity : ≤70%
Power : AC90 ~230V

2. The Basic Parameters and Specifications

3. Optional Propellers

Propeller Type	Description	Dia. of the Propeller	Dia. of the Stir Rod	Lenth of the Stir	Max. Speed
Flat blade style	1 blade	60mm	8mm	400mm	2000rpm
Centrifugal style	2 blades	90mm	8mm	400mm	2000rpm
Propeller style	4 blades	50mm	8mm	400mm	2000rpm
Fan blade style	1 blade	68mm	8mm	400mm	1000rpm

Chapter 3 Preparation

This chapter mainly describes the instrument's mechanical structure, the keyboard and functions of each key, as well as preparations before power on. Please learn this chapter well before the orbital shaker is to be operated at the first time.

1. Structure Description

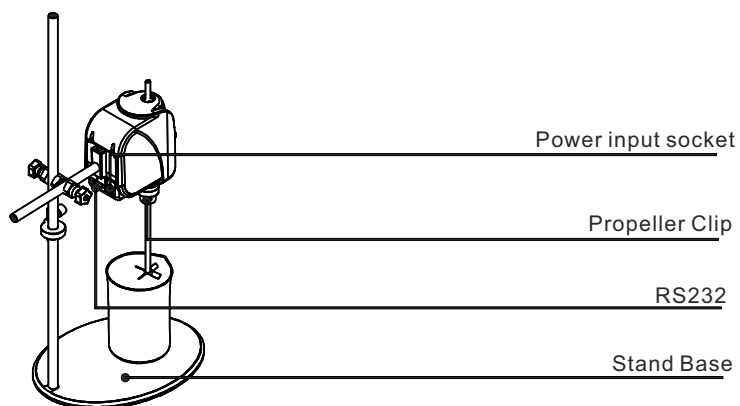
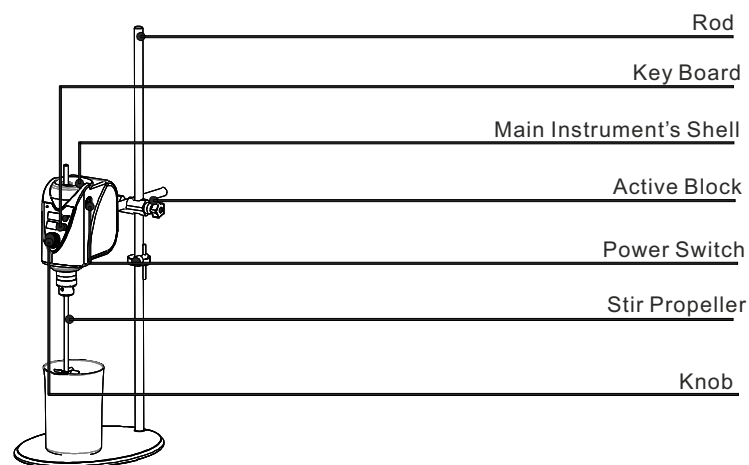

2. Keyboard and Display Panel

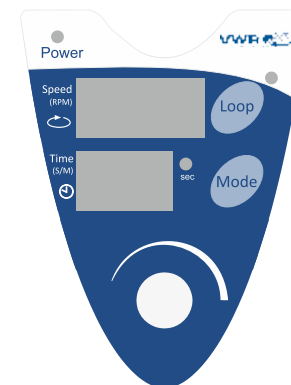

3. Key Function



Clockwise rotate the knob to increase the flickering value, anticlockwise rotate the knob to decrease the flickering value. Press the knob to start or stop operation.

Loop

Press the Loop key, the red loop light at side is on. The instrument alternately clockwise and anticlockwise stirs according to the setting time.

Made

Press the Loop key again, the loop light at side is off. The instrument only clockwise stirs.

4. Installation

1. Put the stand base on a steady, horizontal work table.
2. Make the stand rod through the check ring (refer to figure 1). Adjust the position of the check ring till the hole on its side is matched the hole in the middle of the rod, clockwise twist the screw to fix the checking ring and the rod.

3. Fix the stand rod to the stand base with supplied nut (refer to figure 2 and figure 3).

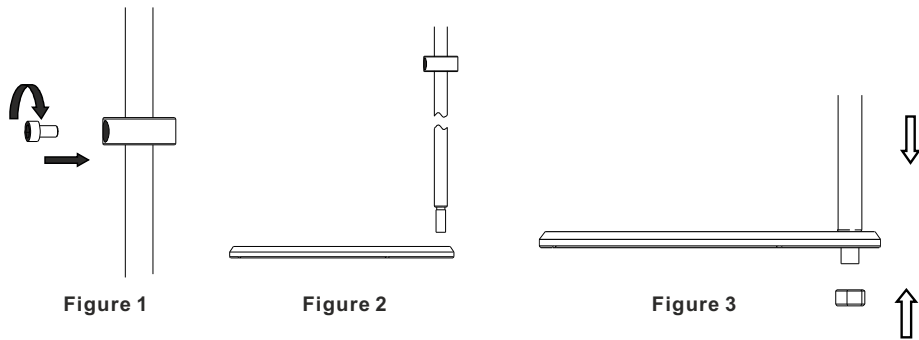

4. Put the bar to the main instrument, twist a screw from up side to fix the bar and the main instrument (refer to figure 4).

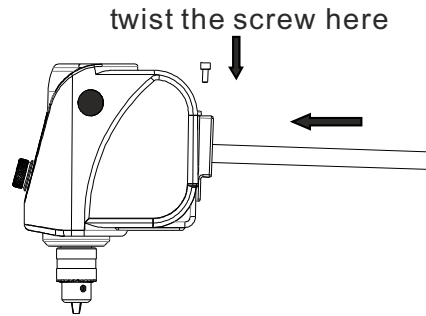

Figure 4

5. Put the bar in the right groove of the active block, use the adjust knob to fix them (refer to figure 5).

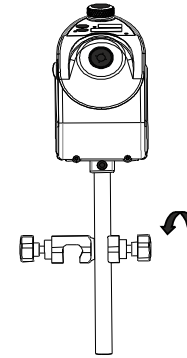

Figure 5

6. Put the stand rod in the left groove of the active block, use the adjust knob to fix them (refer to figure 6).

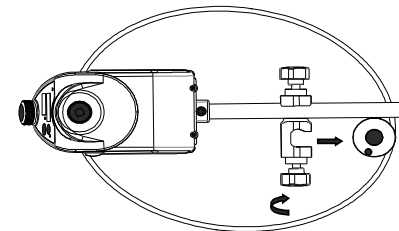

Figure 6

7. Insert the stir propeller to the propeller clip, clockwise rotate the clip till to propeller is tightly fixed to the main instrument (refer to figure 7).

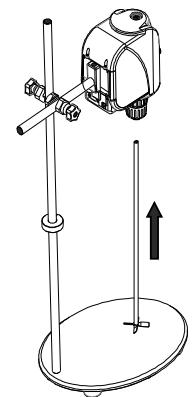



Figure 7

Notice: The position of the main instrument can be adjusted by the active block.

Chapter 4 Operation Guide

1. Speed and Time Setting

- a) Switch on the instrument, all digital of LED display  as the right chart. The instrument enters into the initial program with beep.

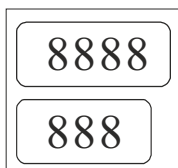

- b) The LED of speed displays last running speed. Refer to the right chart, it is "1280" rpm. Press the Mode key, the last digit "0" flickers. Clockwise rotate the knob to increase the speed value in digit, contrarotate the knob to decrease the speed value in digit. Press the Mode key again, the 3rd digit "8" flickers, rotate the knob to increase/decrease the speed value in tens. Press the Mode key again, the 2nd digit "2" flickers, rotate the knob to increase/decrease the speed value in hundreds.



Press the Mode key again, the last digit of time value flickers

- c) The LED of time displays last setting time. Refer to the right chart, the total running time is "365" min. Press the Mode key after the 2nd digit of speed flickers, the last digit "5" of time value "365" flickers. Clockwise rotate the knob to increase the time value in digit, contrarotate the knob to decrease the value in digit. Press the Mode key again, the 2nd digit "6" of time value flickers, rotate the knob to increase/decrease the time value in tens. And press the Mode key again, the 1st digit "3" flickers, rotate the knob to increase/decrease the time value in hundreds.

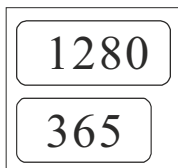

Press the Mode key again, the last digit of speed value flickers.

If it is under Loop mode (the red light at the Loop side is on), press Mode key again, the green light at the time LED display side is on. Refer to the right chart. There are only 2 digits display on the time screen now, and the last digit "5" of "15" flickers. It is the time value of the alternately clockwise and anticlockwise stirring time. It means stirring in 1 direction is "15" seconds. Clockwise rotate the knob to increase the time value in digit, contrarotate the knob to decrease the value in digit. Press the Mode key again, the 1st digit "1" flickers, rotate the knob to increase/decrease the time value in tens.

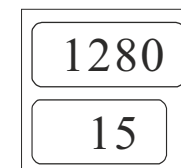

- d) Before the speed reaches the setting value, the green light of power flickers. When the speed reaches the setting value, the green light of power keeps lighting.

NOTICE: The timing value displays 00:00 means running timing is ∞ .

1. Stop / Start

- a) After speed and time value setting finished, press the knob to start operation.
b) Press the knob during operation to stop running.
c) When time is up, the instrument stops running with beep alert.

Chapter 5 Failure Analysis and Trouble Shooting

Failure Analysis and Processing Procedures

No.	Phenomenon	Possible Causes	Processing Procedure
1	No signal display when power on.	No power	Check the power
		Broken switch	Exchange the switch
		Others	Contact with the seller
2	Abnormal vibration during operation	Sample placed not in the middle	Place the sample in the middle
3	Actual speed and displayed speed are not matching	Broken controller	Contact with the seller
4	Display ERR	Speed out of control	Contact with the seller
5	Knob does not work	Broken knob	Contact with the seller

Appendix A: Wiring Diagram of 6000.EU.01

(Below diagram is just for reference. It is subject to change without prior notice.)

